

# calomax

MODEL: KUDOS 6 DUAL FLOW  
KUDOS 9 DUAL FLOW

## INSTALLATION, OPERATION AND SERVICING INSTRUCTIONS

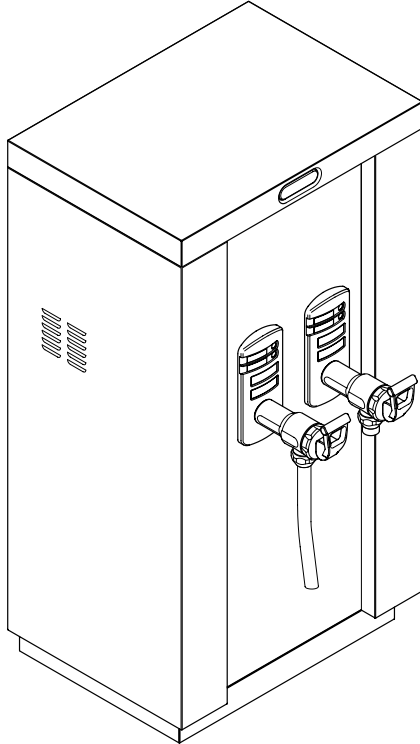

Issue 8  
09/07/13  
DCR 872



Please read these  
instructions carefully  
before operating your  
boiler for the first time

**Calomax Limited**

Lupton Avenue, Leeds LS9 7DD

Tel. 0113 249 6681 Fax. 0113 235 0358

e-mail: [service@calomax.co.uk](mailto:service@calomax.co.uk)

[www.calomax.co.uk](http://www.calomax.co.uk)

CONTENTS	page
INTRODUCTION	3
CHECK LIST	3
APPROVALS	3
CONSTRUCTION	4
<b>INSTALLATION</b>	4
LOCATION	4
COLD WATER INLET	4
DIMENSIONS AND WEIGHTS	5
VENT / OVERFLOW	5
ELECTRICAL CONNECTIONS	6
<b>USER INSTRUCTIONS</b>	6
SCALE	7
GENERAL OPERATION	8
GENERAL NOTES	8
CLEANING	8
ACCESSORIES	9/10/11
<b>SERVICE INSTRUCTIONS</b>	12
EXPLODED DIAGRAMS	15/16
SPARE PARTS	17/18
WIRING DIAGRAMS	19/20
TROUBLE SHOOTING	21
SERVICE HISTORY NOTES	22
WARRANTY	23
PRODUCT SPECIFICATION	24

## INTRODUCTION

Thank you for purchasing a Calomax Kudos range boiler. All our products are designed to give years of simple, reliable operation. To ensure this, it is important that the installation and subsequent servicing is carried out by a suitably qualified engineer in accordance with these instructions.

For assistance in finding a suitable engineer in your area, visit our website, contact our service department on 0113 249 6681 or e-mail: [service@calomax.co.uk](mailto:service@calomax.co.uk)

## CHECK LIST

Before commencing installation, check that the following parts have been supplied with the boiler:

1. WRAS approved flexible water inlet hose suitable for potable water.
2. Status label

## APPROVALS



This product conforms to the CE marking directive 93/68/EEC through compliance with the following standards:



Electromagnetic Compatibility Directive  
Low Voltage Directive 73/23/EEC in accordance with:

**kiwa**  
approved  
product



Approved

BS EN 60335-2-63:1993

Compliance with these standards has been confirmed through testing by an independent NAMAS approved body

Calomax products have been tested and found to comply with the requirements of the Water Supply (Water Fittings) Regulations 1999 for England and Wales Water Bylaws 2000, Scotland and the Water Regulations Ireland.

## CONSTRUCTION

All metallic components of the machine, in direct contact with drinking water are manufactured from high quality 304 grade stainless steel, or non ferrous materials, providing maximum resistance to corrosion.

## INSTALLATION

### LOCATION

The boiler must be installed in a location where access is restricted to operators that are suitably trained, or where untrained operators of the machine can be supervised by trained personnel.

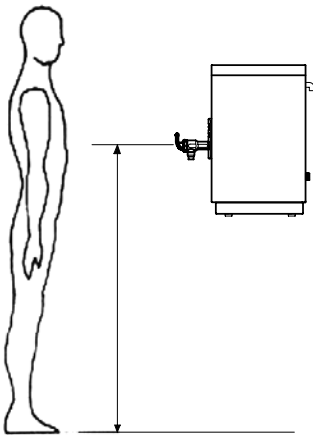

To comply with recommendations from the health and safety executive it is important that due consideration be given to safe operation of the controls of the boiler. The boiler should therefore be mounted in such a manner that the operator can stand directly facing the machine with the controls at a recommended height from the floor to the draw-off tap handle of 1200mm +/- 100mm. Consideration should also be given to the servicing requirements of the machine. The maximum and minimum ambient operating conditions

must be between 5 °C and 35 °C. The appliance is not suitable for installation where a water jet could be used. Install the boiler on a surface suitable for near boiling temperatures and the working weight of the boiler. Allow adequate clearance for ventilation and for the easy removal of the outer casing lid and left hand side panel panel. Calomax Ltd recommend a minimum clearance of 50mm on all sides of the boiler except the left hand side which requires minimum of 150 mm clearance for maintenance. A suitably qualified engineer must install this unit. Plumbing and electrical installation work is involved.

### COLD WATER INLET

To comply with the U.K. Water Supply Regulation a single check-valve must be fitted to the supply.

**BEFORE CONNECTING, THE SUPPLY PIPE MUST BE THOROUGHLY FLUSHED OUT TO ENSURE THAT FOREIGN MATTER DOES NOT BLOCK OR ENTER THE SOLENOID VALVE**

The boiler must be connected to a potable water supply using the food grade hose provided, in a manner which complies with UK water regulations. The hose should be connected to a ½” (15mm) drinking water supply via an appropriate isolating valve. The supply must provide a constant pressure of between 20 KPa and 1000 KPa (0.2 to 10 Bar).

If the water supply contains excessive solids in suspension it is recommended that a fine mesh “in line” water filter is fitted in the pipe

**DIMENSIONS AND WEIGHTS**

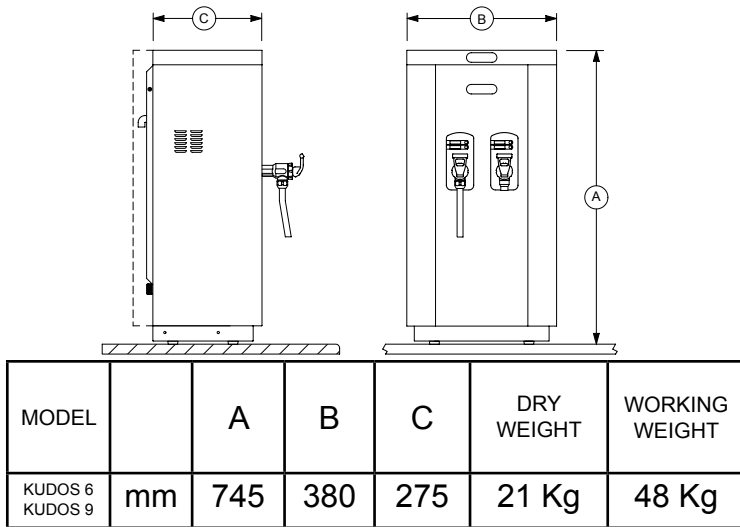

ALL DIMENSIONS ARE APPROXIMATE

**VENT & OVERFLOW**

The vent / overflow pipe must be extended and laid with a **continuous fall**, discharging to a safe and visible point. The pipe should not be directly connected to a closed waste, as taste problems may occur and should never be allowed to become blocked or restricted. 15mm copper or ‘Speedfit’ pipe should be used. If the machine is operated without

the overflow pipe being extended as advised, any subsequent damage incurred will be the responsibility of the installer.

## **ELECTRICAL CONNECTIONS**

Kudos6 Dual-flow boilers require fixed wiring to the rear terminal block. A means of disconnection must be provided in which at least 3mm separation between the live and neutral poles of the supply exists.

Kudos9 Dual-flow boilers require fixed wiring to a 3 phase 4 wire supply in which at least 3mm separation exists in the three phases of the supply (but not the neutral).

The installation of a residual current device (RCD) having a rated residual operating current not exceeding 30 mA is advisable.

## **USER INSTRUCTIONS**



During normal operation some external parts will become very hot, particularly the tap body. Care must be taken to avoid injury, a burn or scald.

### **Commissioning**

Turn on the water supply and then switch on the electrical supply. The Wait/Ready light will flash yellow and the unit will pulse with water (8L/Min). When water reaches the normal operating level sensor, the solenoid will be disabled and the element will be energised. When a band of water around the draw off tap has reached the normal operating temperature, the Wait/Ready light will show solid yellow colour (indicating water available). The elements will remain energised until the full capacity has reached normal operating temperature, indicated by the wait/ready light turning to solid a orange colour.

### **Subsequent Use**

After the boiler has finished the commissioning cycle and water is drawn from the tap, water will be replaced in pulses automatically by the solenoid

The element(s) may be also be energized at the same time. If water is drawn from the machine but boiling water is still available, the Wait/Ready light will be illuminated solid yellow. If full draw off capacity is removed the boiler may cool, indicated by the Wait/Ready light flashing yellow.

**Note:**

When the green service indicator light on the front of the boiler is showing solid colour, the header tank sensor has been starved of water for in excess of 30 seconds and the bottom thermistor has been disabled. To reinstate normal operation the water supply needs to be re-applied.

If the service indicator light flashes, this indicates that the water level has reached the high level sensor and the likelihood is that the normal level sensor requires de-scaling, or the machine has over-filled due to debris trapped in the solenoid valve. The debris can be removed by drawing plenty of water from the dispense tap, causing the solenoid valve to operate and flush out the obstruction. The machine will reset itself once the problem has cleared. If this does not rectify the problem, turn off the water supply and remove the flexible hose to check for debris in the valve's filter. When the service light is flashing, the element is disabled and the boiler may cool. For further assistance, contact our service department on 0113 249 6681, or e-mail [service@calomax.co.uk](mailto:service@calomax.co.uk).

## **SCALE**

The production of scale is a natural phenomenon and commonly occurs in hot water systems. The nature of the scale produced and its rate of formation varies widely throughout the country.

To ensure continuous, reliable operation, the boiler should be regularly de-scaled by a suitably qualified engineer. Suitable chemical de-scalants must only be used if the manufacturers recommendations are strictly adhered to. This is to prevent health and safety issues, taste problems and potential damage to the appliance. Misuse of such chemicals is not covered by the product warranty.

The Kudos range of boilers benefit from an integral scale inhibitor. **This is not** a scale eliminator and its effects will differ according to the water quality in your area. To ensure trouble free operation, periodically check for scale inside the boiling chamber. The production of scale is a natural phenomenon and some de-scaling may be required within the first 12 months. This is not covered under the products warranty as it is not a fault.

## GENERAL OPERATION

- Hold a cup below the tap or place large vessels on the drip tray. Care must be taken to avoid injury through splashing or over-filling.
- To begin filling, pull the handle forward or push it backward – hot water begins to flow. If the tap is opened fully it can be locked open (for filling large vessels) in this state the boiler must never be left unattended.
- To stop filling, release the handle so it returns to the closed position. AS STANDARD THIS BOILER IS FITTED WITH AN EXTENDED NOZZLE DESIGNED FOR FILLING LARGE VESSELS. DUE TO THIS, WATER WILL CONTINUE TO FLOW FOR SEVERAL SECONDS AFTER THE TAP HAS BEEN CLOSED NEVER PASS YOUR HAND BENEATH THE NOZZLE.

## GENERAL NOTES

- Please retain these instructions for future reference
- Ensure that a suitable drip tray is positioned below the tap nozzle. This will help keep the surrounding work surfaces and floor free from drips or splashes. Various options are available and are outlined on the Accessories page of this booklet (page 9).
- All de-scaling and servicing must be performed by a suitably qualified engineer.

## CLEANING



Avoid using any abrasive materials. Wiping the outer casing with a damp cloth should be sufficient. Some stainless steel cleaning products may not be suitable for plastic and must not come in contact with the plastic fascia. Always disconnect the electrical supply before cleaning.

**NEVER USE A SPRAY JET OR ANY OTHER METHOD WHICH COULD CAUSE WATER TO ENTER THE ELECTRICAL CHAMBER.**



# Accessories

(To suit all Kudos models unless stated otherwise)

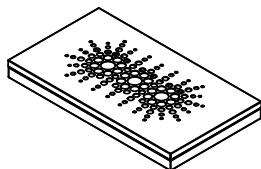

## Worktop-mounting Stainless Steel drip tray

Ref. SSDTK (freestanding)  
SSDTWDK (with drain outlet)

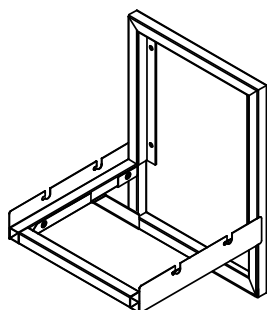

## Wall-mounting bracket (for boiler)

Ref. KWMBK

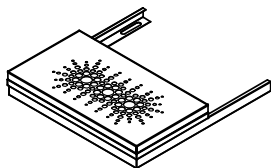
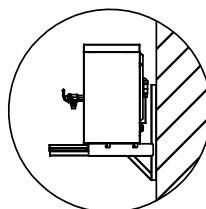

## Stainless Steel drip tray for Wall-mounting bracket (above)

Ref. KWMBDTK (free standing)  
KWMBDTWDK (with drain outlet)

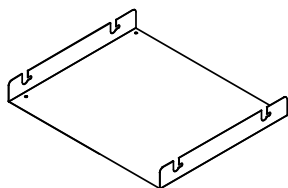

## Boiler securing clamp

(To fix boiler to a worktop)

Ref. KC14MM

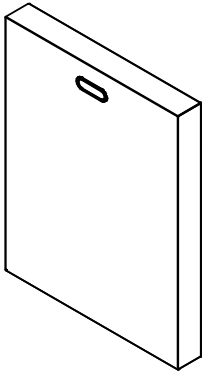

## Back panels

(To conceal water & electrical connections)

REF. K9BAC for Kudos6 Dual Flow & Kudos9 Dual Flow)

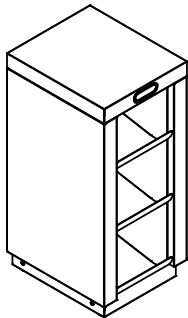
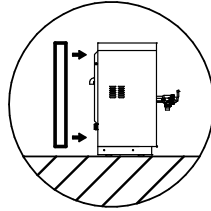

## Ingredient caddy

Ref. IC3 (3 bay) - *as shown*  
IC4 (4 bay)

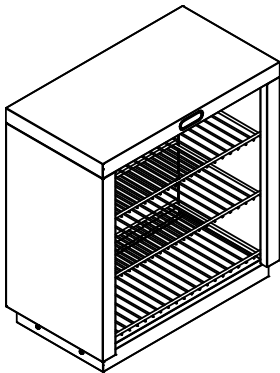

## Shelf unit

(For storing cups / saucers etc.)

Ref. SHU



## SERVICE INSTRUCTIONS

When the green service indicator light on the front of the boiler is showing solid colour, the header tank sensor has been starved of water for in excess of 30 seconds and the bottom thermistor & bottom element(s) have been disabled. To reinstate normal operation the water supply needs to be re-applied.

If the service indicator light flashes, this indicates that the water level has reached the high level sensor and the likelihood is that the normal level sensor requires de-scaling, or the machine has over-filled due to debris trapped in the solenoid valve. The debris can be removed by drawing plenty of water from the dispense tap, causing the solenoid valve to operate and flush out the obstruction. The machine will reset itself once the problem has cleared. If this does not rectify the problem, turn off the water supply and remove the flexible hose to check for debris in the valve's filter. When the service light is flashing, the element is disabled and the boiler may cool. For further assistance, contact our service department on 0113 249 6681, e-mail [service@calomax.co.uk](mailto:service@calomax.co.uk). or find a local service engineer at [www.calomax.co.uk](http://www.calomax.co.uk)

**Access to internal components can be gained by the removal of the outer casing lid and left hand side panel. Once the outer casing is removed, access to the Service Area has been gained. This access must be restricted to persons having knowledge and practical experience of the appliance, in particular as far as safety and hygiene are concerned.**

### De-scale

To gain access to internal components, the body lid must be removed. Break the lid gasket seal and lift it clear of the body.

**Note:** Whenever the body lid has been removed from the boiler a new lid gasket may be required to ensure a steam-tight joint. Damage to the unit caused by a poor lid seal is not covered by warranty.

Scale deposits should be removed from all internal surfaces, particularly the heating element, thermistors and level sensors by gently tapping or scraping. If the deposits are soft, use a nylon pad and flush out. Abrasive cleaning materials containing scouring powders and detergents must not be used, such materials can cause taste problems.

Suitable chemical de-scalants must only be used in accordance with the manufacturers recommendations. This will prevent health and safety issues, taste problems and potential damage to the appliance. All trace of these chemicals must be removed before re-commissioning the unit. Misuse of such chemicals is not covered by the product warranty.

**IMPORTANT Before re-commissioning the boiler it is important that all scale and moisture is removed from the level sensors and insulating gaskets, to avoid a false signal being transmitted through the scale to the boiler body. Failure to remove this scale and/or moisture could cause the sensor to indicate to the PCB that water is covering the element, whether or not water is present. In this situation the PCB could energise the element causing failure. If in doubt, protect the element by hand filling with water to the level of the draw-off tap before switching on the electrical supply to the boiler.**

## **General function**

The printed circuit board (PCB) controls the heating and filling functions of the boiler by monitoring the thermistors and level sensors. The PCB also controls the external light unit to indicate the current state of the boiler. Red and yellow LED'S on the circuit board indicate whether the PCB has energised the elements or solenoid respectively.

Should an element fail and need to be replaced, it may be

necessary to replace the lid gasket to ensure a reliable steam-tight seal. **Note: the elements have a permanent 'Live' feed, and the 'Neutrals' are switched.**

### **Printed Circuit Board replacement (PCB)**

In the event of a PCB failing and a replacement being required, full instructions will be supplied. It is important to note however, that the Triac PCB's must be securely mounted against the copper heat-sinks to ensure reliable heat dissipation. Heat transfer compound is also supplied with all replacement circuit boards.

### **Adjusting the Water Temperature Set Point**

The temperature potentiometer (Pot) is pre-set at Calomax and will only require adjustment in exceptional circumstances. Contact Calomax for advice.

Water boils at different temperatures depending on barometric pressure. The temperature should not be tuned higher than 98°C, or over boiling may occur during low barometric pressure conditions, causing the unit to trip the overheat cut-out device.

# Exploded parts view (To be read in conjunction with the spare parts list) Kudos6 Dual Flow

If parts required  
are not identified,  
please contact  
Calomax Limited

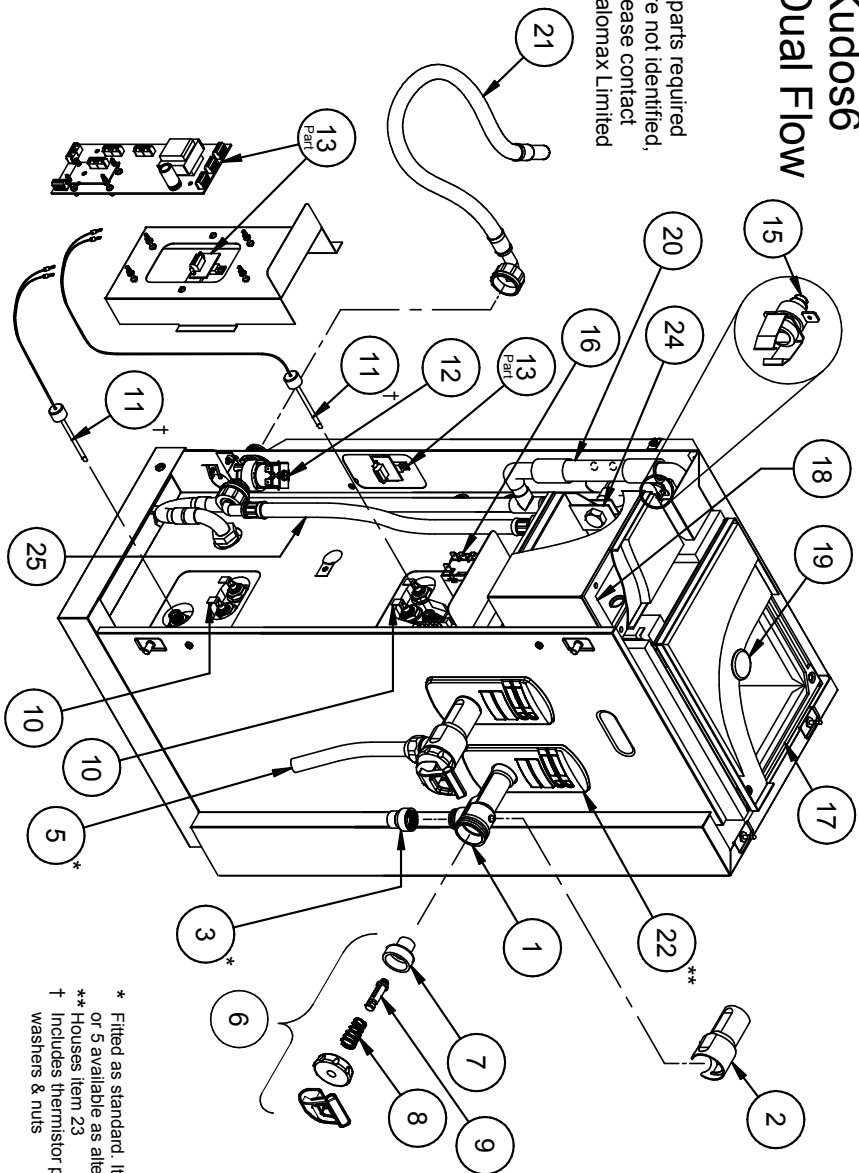

\* Fitted as standard. Items 3, 4  
or 5 available as alternatives  
\*\* Houses item 23  
+ Includes thermostat pocket, all  
washers & nuts

# Exploded parts view (To be read in conjunction with the spare parts list) Kudos9 Dual Flow

If parts required are not identified, please contact Calomax Limited

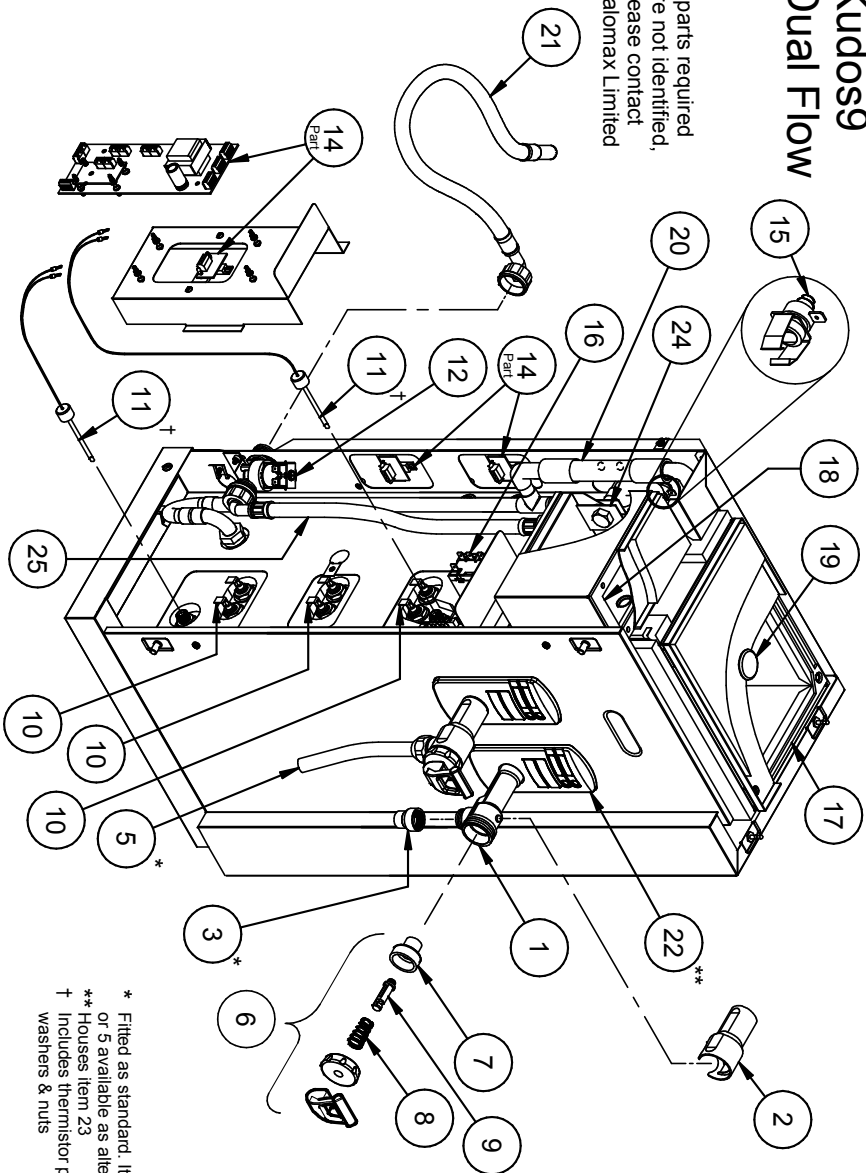

\* Fitted as standard. Items 3, 4 or 5 available as alternatives  
 \*\* Houses item 23  
 † Includes thermostat pocket, all washers & nuts



Spare parts are usually available ex-stock.  
Please quote Model & Serial Number.

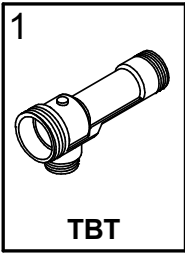

**1**  
**TBT**  
DRAW OFF TAP  
BODY

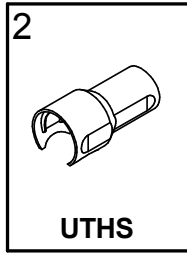

**2**  
**UTHS**  
TAP BODY HEAT  
SHIELD

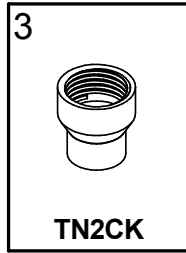

**3**  
**TN2CK**  
SLOW-FILL NOZZLE

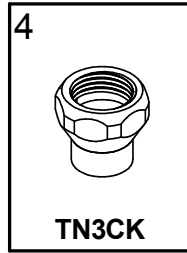

**4**  
**TN3CK**  
FAST-FILL NOZZLE

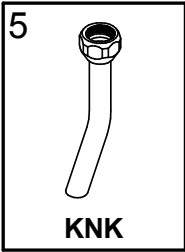

**5**  
**KNK**  
EXTENDED  
FAST-FILL NOZZLE

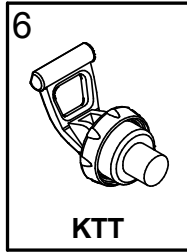

**6**  
**KTT**  
TAP TOP ASSEMBLY

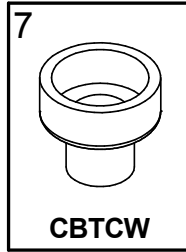

**7**  
**CBTCW**  
TAP CUP WASHER

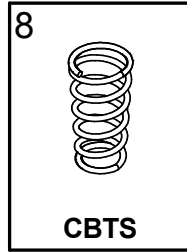

**8**  
**CBTS**  
TAP SPRING

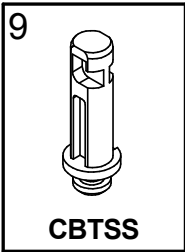

**9**  
**CBTSS**  
TAP SLOTTED  
STEM

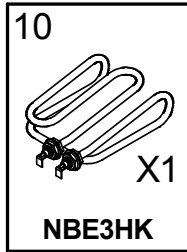

**10**  
**NBE3HK**  
3kW ELEMENT

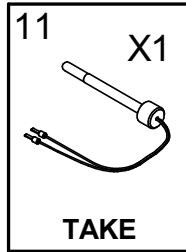

**11** X1  
**TAKE**  
THERMISTOR  
ASSEMBLY KIT

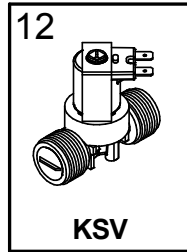

**12**  
**KSV**  
SOLENOID VALVE

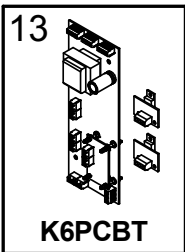

**13**  
**K6PCBT**  
PRINTED CIRCUIT  
BOARD-6kW Inc.TRIACS

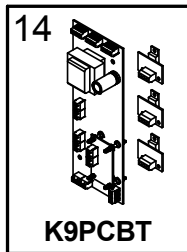

**14**  
**K9PCBT**  
PRINTED CIRCUIT  
BOARD-9kW Inc.TRIACS

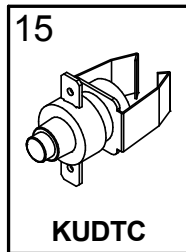

**15**  
**KUDTC**  
MANUAL RESET  
THERMAL CUTOUT

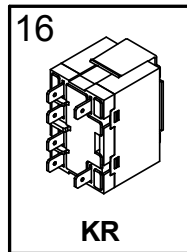

**16**  
**KR**  
RELAY

Spare parts are usually available ex-stock.  
Please quote Model & Serial Number.

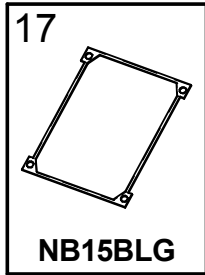

BODY LID GASKET

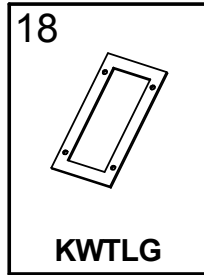

WATER TANK  
GASKET

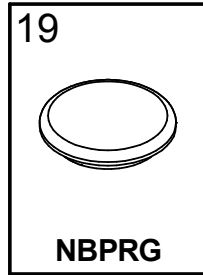

BODY LID  
GROMMET

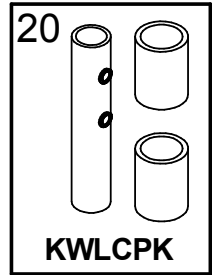

WATER LEVEL  
CONTROL PIPE

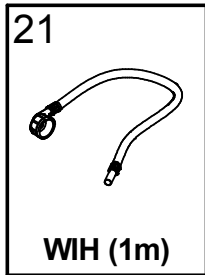

WATER INLET  
HOSE

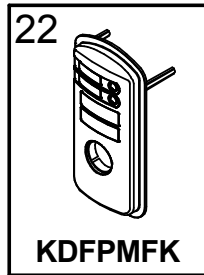

PLASTIC FASCIA FOR  
DUAL FLOW BOILERS

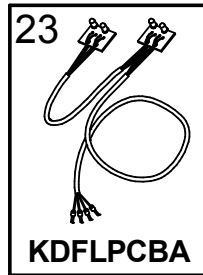

LIGHT PCB FOR DUAL  
FLOW BOILERS

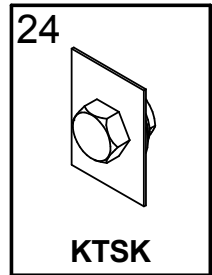

TANK SENSOR KIT

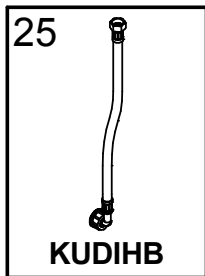

INTERNAL HOSE  
ASSEMBLY  
(K6/DF & K9/DF)

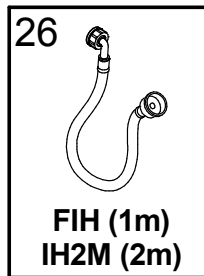

WATER INLET  
HOSE



# Wiring Schematic for Kudos-9 Dual Flow Water Boiler

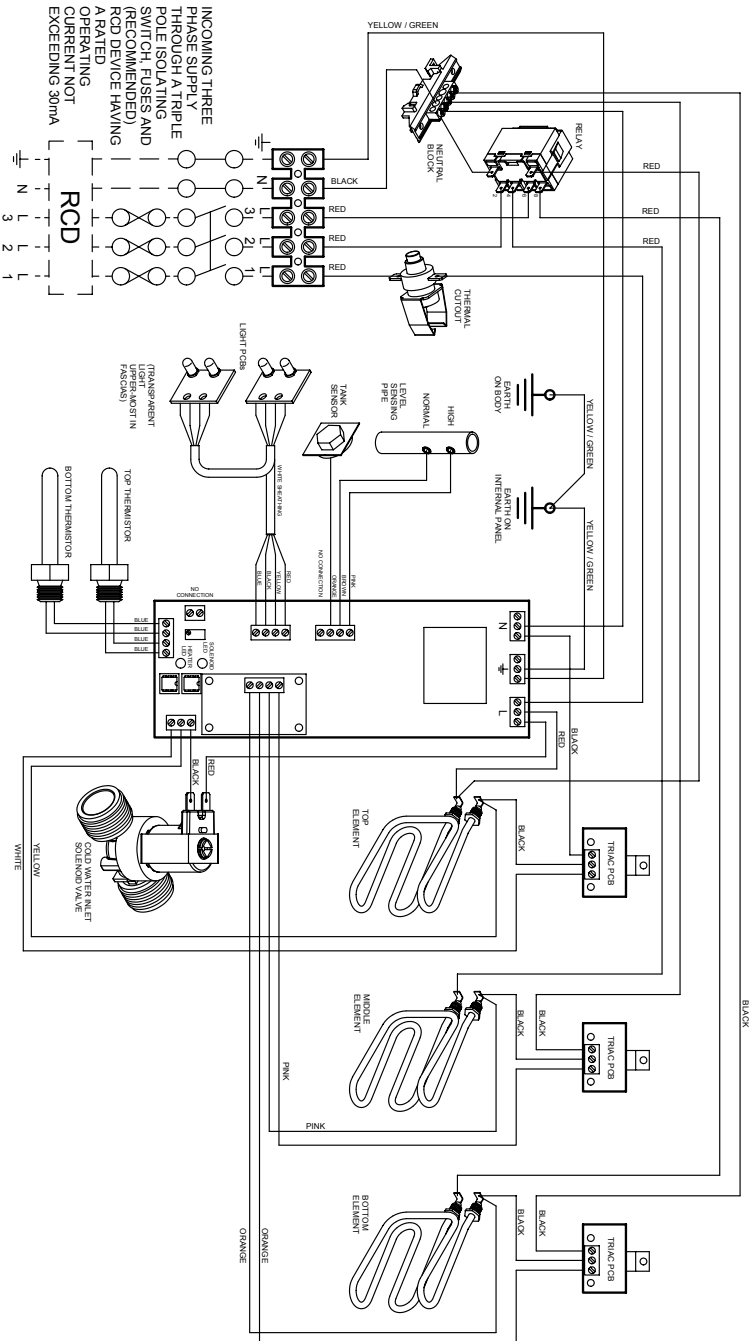

# BASIC TROUBLE SHOOTING

Symptoms	Possible Cause	Remedy
No boiling water available	Broken tap top	Replace tap top (or component)
	Normal level sensor holding signal	De-scale
	Thermal cut-out tripped (no light)	Reset and check for faults
	Element failed	Replace element
Thermal cut-out trips regularly	Excessive internal scale. (See 'De-Scale' page 12)	De-scale the boiler (Particularly thermistors)
	Faulty wiring to thermistors / faulty thermistors	Repair / replace as required
	Temperature controller needs adjusting	Lower operating temperature
	Element failed to earth	Replace element
	Defective Printed Circuit Board	Replace Circuit Board
Overflows	Dirt in solenoid valve.	Clean solenoid filter / or replace solenoid, "work the boiler" -see Service Instructions (page 12).
	Level sensors require de-scaling or replacing	De-scale / replace sensors
	Printed circuit board faulty	Replace P.C.B

## SERVICE HISTORY AND NOTES

## **WARRANTY GUARANTEE (UK Mainland customers only)**

Calomax have manufactured water boilers in the UK for over 50 years. We are proud of our products and the back-up service we provide

Properly maintained and serviced, a Calomax boiler should last many years and we have no hesitation in providing a full 12 months (mainland U.K.) parts and labour warranty for all models. Please complete and return the enclosed product registration form as soon as possible to activate this, or register online at [www.calomax.co.uk](http://www.calomax.co.uk).

In addition, the Clipper, Kudos and Quantum models carry an additional 12 month back to base warranty.

Some factors are beyond our control and would invalidate the warranty offered. These include:

- Incorrect installation
- High / Low water pressure
- Incorrect voltage supply
- Accidental damage
- Limescale build-up

The last item can be a particular problem for water dispensing equipment in hard-water areas. All hot water equipment should be serviced and de-scaled by approved organisations on a regular basis to avoid a damaging build-up of limescale.

Although our boilers incorporate scale-inhibitor technology, we recommend that a taste, odour and scale filter should be fitted where appropriate.

Please visit our website [www.calomax.co.uk](http://www.calomax.co.uk) for details of our Service Partner Network and the range of filters and accessories available

PLEASE ENTER MODEL AND SERIAL NUMBER FOR  
FUTURE REFERENCE

Model	
Serial Number	
Draw off Capacity	22 Litres
Heat-up Time (First fill to full capacity)	- K6/DF 31 Minutes - K9/DF 23 Minutes
Average Flow rate from tap	
Extended nozzle	8.5 Litres / Minute
Fast flow nozzle	6 Litres / Minute
Slow flow nozzle	3.5 Litres / Minute
Voltage - K6/DF - K9/DF	220 - 240 V ac 50-60 Hz 1 PHASE 415 V ac 50-60 Hz 3 PHASE
Power rating - K6/DF - K9/DF	6kW (MAX) 9kW (MAX)
Note: All measurements are approximate.	

**PLEASE CONTACT OUR SERVICE DEPARTMENT FOR ASSISTANCE**

Calomax Limited, Lupton Avenue, Leeds LS9 7DD  
Tel: 0113 249 6681  
Fax: 0113 235 0358  
e-mail: [service@calomax.co.uk](mailto:service@calomax.co.uk)